



**GOVERNMENT OF INDIA
MINISTRY OF RAILWAYS**

**REPORT ON TESTING OF INDIGENOUS PONGAMIA OIL
BASED BIODIESEL AS ALTERNATIVE TRACTION FUEL ON
3100 HP ALCO 16 V FE ENGINE
(Test Bed Results)**

Report No. TR/ED/2010/207
(March 2010)

**ENGINE DEVELOPMENT DIRECTORATE
RESEARCH DESIGNS & STANDARDS ORGANISATION
MANAK NAGAR, LUCKNOW – 226 011**

TABLE OF CONTENTS

Synopsis	1
Introduction	2
Quality Assurance	2 - 3
Engine Configuration	4
Test Procedure	5
Test Result Analysis	6 -16
Conclusion	17

SYNOPSIS:

Use of Bio-Diesel as Traction Fuel is expected to provide Energy security to country, reduce dependence on fossil based fuels and conserve the environment. Indian Railways is the single largest user of High Speed Diesel in the country with an annual consumption of 2.2 Billion Litre per year. With the use of Bio-Diesel, savings is expected in terms of Foreign Exchange since most of the petroleum products in India are imported. However, for this it is essential that detailed Engine Characterization with various Bio-Diesels be conducted on Rail Traction Engines available with Indian Railways. Thus, certain representative native non-edible oils based Bio-Diesel have been chosen for Engine Characterization.

This Report pertains to characterization of 3100 HP ALCO 16 V Engine with 'Pongamia Oil' based Bio-Diesel and its Blends. The Performance Studies with different Blends of 'Pongamia Oil' based Bio-Diesel carried out on 3100 HP ALCO Engine reveal the following:

1. There is no change in Horsepower for various Blends of Bio-Diesel. Even B100 Bio-Diesel is capable of developing full Horsepower on 3100 HP ALCO Engine.
2. Brake Specific Fuel Consumption (BSFC) showed an increasing trend with higher Blends of Bio-Diesel as compared to Petro-Diesel. BSFC has increased by 12.8% at 8th Notch with B100 Bio-Diesel as compared to Petro-Diesel, which is due to 10 -12% Lower Calorific value of Ester Fuel (Bio-Diesel) as compared to Petro-Diesel.
3. Total Hydrocarbon (THC) Emissions revealed decreasing trend with higher Blends of Bio-Diesel.
4. NOx Emissions generally increase with higher Blends of Bio-Diesel due to higher viscosity of Bio-Diesel leading to earlier Injection/Combustion and Bio-Diesel being oxygenated Fuel facilitating NOx formation. All Blends of Bio-Diesel show higher NOx levels after 2nd Notch as compared to Normal HSD.
5. CO Emissions have reduced by 27.5% at 8th Notch with B100 Bio-Diesel as compared to HSD. This reduction in CO Emissions at 8th Notch with B100 Bio-Diesel is due to complete oxidation as compared to HSD. Increase in CO Emissions from 3rd to 5th Notch for various blends of Bio-Diesel and HSD is noticed.
6. Smoke Opacity of Exhaust showed decreasing trend with higher Blends of Bio-Diesel with 63.8% reduction with B100 Bio-Diesel as compared to Normal HSD (at 8th Notch).
7. Average Cylinder Head Exhaust Temperatures have varied over narrow range and were found below upper limit of 450 °C.
8. The performance of Fuel Injection Equipment and Rubber/Brass Components need to be monitored with usage of Bio-Diesel. Proper Handling, Storage and Transportation of Bio-Diesel need to be ensured so that Bio-Diesel does not deteriorate due to oxidation.

INTRODUCTION:

Bio-Diesel is an environmental friendly fuel similar to Petro-Diesel in combustion properties. Increasing environmental concern and diminishing petroleum reserves are the driving forces to promote Bio-Diesel as an alternative renewable transportation fuel. Bio-Diesel is promising alternative fuel which is bio-degradable, non-toxic and essentially free of Sulfur and Aromatics. The Engine performance and response to different type of Bio-Diesel depend on the Feedstock from which Bio-Diesel has been produced. It was, therefore, imperative for Engine Development Directorate to undertake detailed Engine Characterization of ALCO and EMD Diesel Engine with different Feedstock based Bio-Diesel.

Engine Characterization of ALCO and EMD 16 V Engine at 3100 HP and 4000 HP rating respectively has been undertaken in Engine Development Directorate with the following indigenously produced Bio-Diesel based on Non-edible Feedstocks:

- Waste Fish Fatty Acid Methyl Ester (WFFAME)
- Waste Mahua Oil Fatty Acid Methyl Ester (WMFAME)
- Waste Cotton Seed Fatty Acid Methyl Ester (WCFAME)
- Pongamia Fatty Acid Methyl Ester (PFAME)

This Report pertains to Characterization of 16 Cylinder ALCO 3100 HP Diesel Engine with indigenously produced 'Pongamia Fatty Acids Methyl Ester (PFAME)'.

QUALITY ASSURANCE:

(A) The Test Result for various Parameters of 'Pongamia' Feed-stock based Bio-Diesel after storage for more than 3 Months without Nitrogen Cover are as under:

SN	Characteristic	Unit	Method of Test as per IS: 15607- 2005	Limit	Pongamia Fatty Acid Methyl Ester as Tested by M/s IOC
1.	Density (at 15°C)	Kg/m ³	ISO 3675, ISO 12185, D 4052 and IS 1448 (P:16/P:32)	860-900	880
2.	Kinematic Viscosity (at 40°C)	cSt	ISO 3104 and IS 1448 (P:25)	2.5-6.0	5.178
3.	Flash Point (PMCC)	°C (min.)	IS 1448 (P:21)	120	157
4.	Sulphur	mg/Kg (max.)	ASTM D-5453 and IS 1448 (P:83)	50.0	26
5.	Carbon Residue (Ramsbottom)	% by Mass (max.)	ASTM D-4530 and ISO 10370	0.05	0.05
6.	Sulphated Ash	% by Mass (max.)	ISO 6245 and IS 1448 (P:4)	0.02	0.018
7.	Water Content	mg/Kg	ASTM D-2709, ISO 3733, ISO 6296 and IS 1448 (P:40)	500	480

8.	Total Contamination	mg/Kg (max.)	EN 12662	24	20
9.	Copper Corrosion	3 hrs at 50°C (max.)	ISO 2160 and IS 1448 (P:15)	1	1
10.	Cetane No.		IS 5156 and IS 1448 (P:9)	51 (min.)	54
11.	Acid Value	mg KOH/gm, (max.)	IS-1448 (P:1 / Sec 1)	0.50	0.61
12.	Methanol	% by Mass, (max.)	EN 14110	0.20	0.025
13.	Free Glycerol	% by Mass, (Max.)	ASTM D-6584	0.02	Nil
14.	Total Glycerol	% by Mass, (max.)	ASTM D-6584	0.25	0.0329
15.	Phosphorous	mg/Kg (max.)	ASTM D-4951	10.0	1
16.	Oxidation Stability (at 110°C)	hrs	EN 14112	6 (min.)	1.27
17.	Sodium & Potassium	mg/Kg (max.)	EN 14108 and EN 14109	To report	11 & 0
18.	Calcium & Magnesium	mg/Kg (max.)	-	To report	1 & 1

Table 1 : Test of PFAME after more than Three months storage without any Nitrogen Cover

It can be seen from the above Table that after storage for more than three months there has been deterioration in properties of Bio-Diesel. Oxidation Stability has decreased due to non-availability of any Nitrogen cover during storage and no Anti-Oxidation Additive added to Bio-Diesel. Acid Value has deteriorated which indicates degradation of Bio-Diesel and generation of Free Fatty Acids.

(B) Pongamia Bio-Diesel Fuel Properties:

The Fuel Properties of Pongamia Bio-Diesel was determined by Gas Chromatography by M/s Indian Oil Corporation Ltd. (R&D Centre), Faridabad and the details are as under:

Major Fatty Acid	Systemic Name	Formula	Structure	Weight %
Palmitic	Hexadecanoic	C ₁₆ H ₃₂ O ₂	16:0	46.3
Stearic	Octadecanoic	C ₁₈ H ₃₆ O ₂	18:0	5.9
Oleic	<i>cis</i> -9-Octadecenoic	C ₁₈ H ₃₄ O ₂	18:1	33.0
Linoleic	<i>cis</i> -9, <i>cis</i> -12-Octadecadienoic	C ₁₈ H ₃₂ O ₂	18:2	14.8

Table 2: Fatty Acid Profile of Pongamia Oil Bio-Diesel

ENGINE CONFIGURATION:

The Engine Configuration used for Testing is as given below:

1.	Engine	16 Cylinder ALCO V Engine with Stiffer Unit Camshaft (SUCS)
2.	Rated HP	3100
3.	Engine RPM	400 – 1050
4.	Camshaft	Stiffer Unit Camshaft
5.	Fuel Injection Equipment	17 mm Plunger Diameter Fuel Injection Pump
6.	Turbocharger	ABB TPR-61A
7.	Piston	M/s FMGIL Make Steel Cap (11.75 CR)
8.	Ring Pack	M/s Kaydon FE
9.	Lube oil Cooler	3100 HP
10.	Exhaust Manifold	3 Entry Stream Line
11.	Cylinder Head	251 Plus
12.	Engine Lubricating Oil	RR 606 MG (M/s IOC)
13.	After Cooler	Large Aftercooler (16 Rows)

Table 3: Engine Configuration used for Testing Bio-Diesel

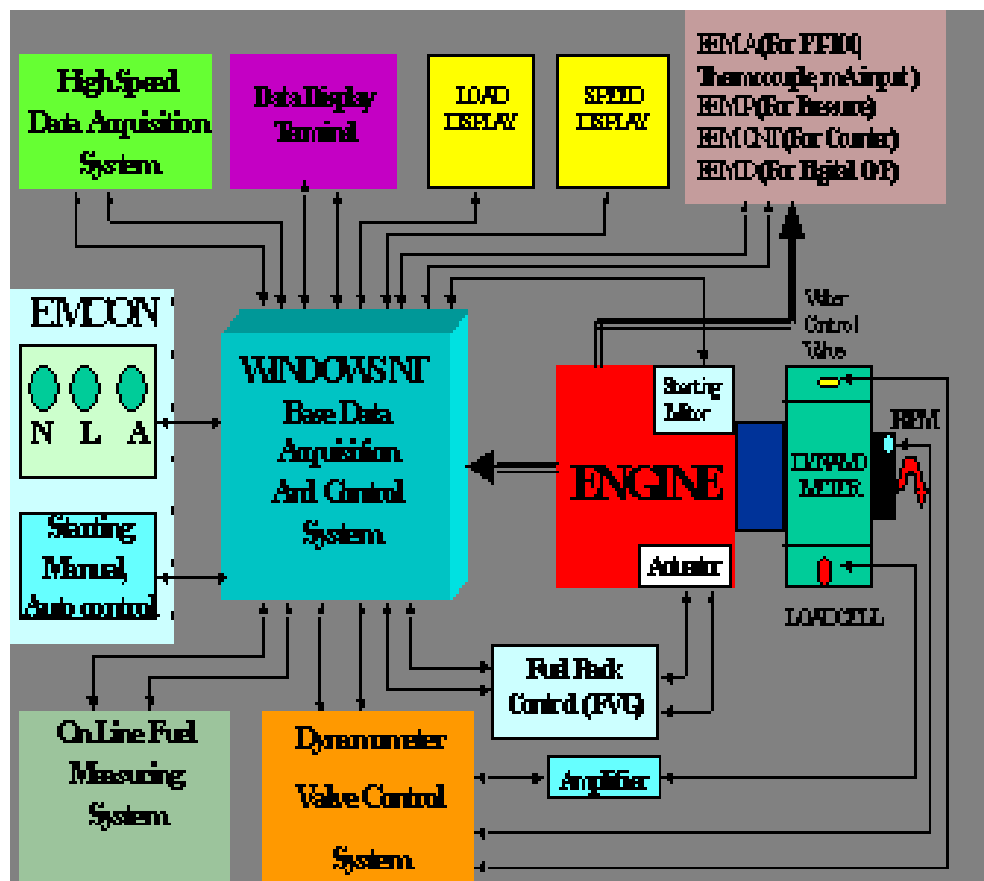

Figure 1: Schematic of Engine Test and Control Configuration

TEST PROCEDURE:

Necessary Instrumentation was provided for measuring Exhaust Gas Temperature, Engine Oil Temperature, Fuel Consumption and various other Engine Parameters. The performance of Bio-Diesel was evaluated in terms of Fuel Consumption, Exhaust Emissions and Power. Fuel Consumption and Power was measured for each Engine-operating Notch. The Engine was run for sufficiently long duration to ensure Thermal stabilization before taking Specific Fuel Consumption (SFC) and Emission measurements.

Engine Test Points

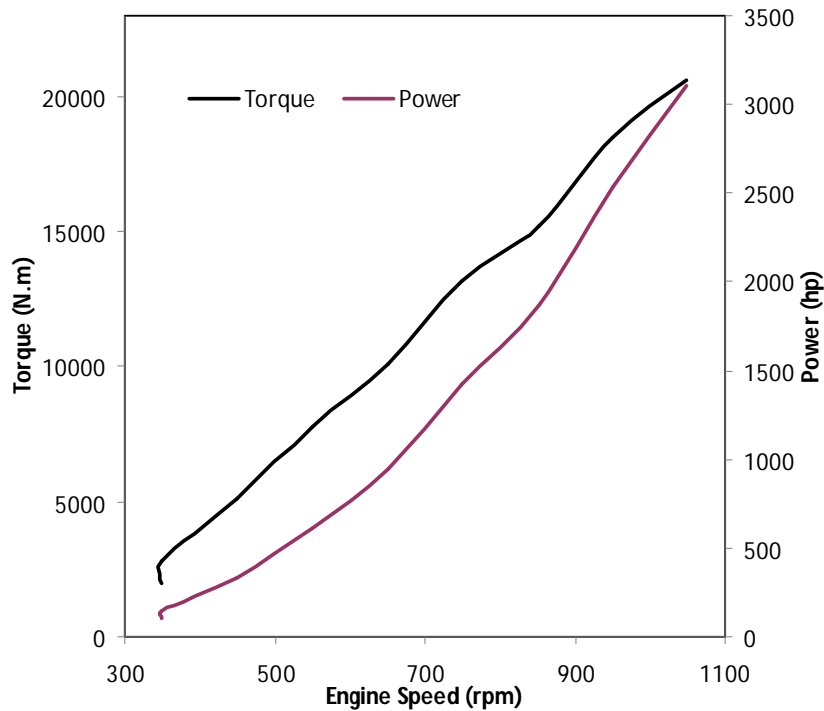

Figure 2: Engine Test Points

Figure 2 above shows the Engine Operating Line which has been used for Engine Characterisation. Table 4 indicates Engine Test Points.

Engine Notch	RPM	Torque (N-m)	Horsepower
8 th	1050	20626	3100
7 th	950	18120	2500
6 th	850	15150	1870
5 th	750	13180	1430
4 th	650	10031	950
3 rd	550	7780	615
2 nd	450	5152	330
1 st	350	2845	145
Idle	350	2013	105

Table 4: Engine Test Points

TEST RESULT ANALYSIS:

Results obtained in this study with Petro-Diesel, neat Bio-Diesel and different Bio-Diesel Blends are deliberated upon with respect to Engine Performance and Emissions.

The Testing was carried out on 16-Cylinder Test Bed. Test Matrix was planned with Petro-Diesel and Bio-Diesel in various volume proportions. Initially, the Base Line Data was generated by testing with Petro-Diesel and carrying out measurement of all the requisite parameters. Subsequently, B10, B20 and B50 Blends of Bio-Diesel and neat Bio-Diesel (B100) were used as Fuel and the various Parameters of Engine performance were monitored.

Major Engine Performance Parameters

PARAMETER	High Speed Diesel (HSD)	Bio-Diesel Blends with High Speed Diesel (HSD)			
		B10	B20	B50	B100
Horsepower (HP)	3103.6	3088.5	3098.2	3087.3	3101.7
BSFC (gm/bhp-hr)	157.0	158.6	160.3	167.8	177.1
Exhaust Gas Temperature (°C)	379.5	347.9	352.5	348.7	351.8
Firing Pressure (bar)	119.3	120.2	120.1	121.7	119.8

Table 5: Summary of Result for Major Engine Performance Parameters at 8th Engine Notch

As can be seen from the above Table, the Engine has maintained full Horsepower with all the Bio-Diesel Blends including pure Bio-Diesel (i.e. B100). The following observations are made:

- Brake Specific Fuel Consumption (BSFC) has increased from 157.0 gm/bhp-hr (with HSD) to 177.1 gm/bhp-hr (at B100 Blend), which is an increase of 12.8%. The Lower Heating Value (LHV) of Bio-Diesel is 10-12% less as compared to HSD and has resulted in increase in Brake Specific Fuel Consumption.
- Exhaust Gas Temperature has remained at the same level. There is no significant difference in Exhaust Gas Temperature with HSD and different Bio-Diesel Blends.
- Firing Pressure did not change significantly.

Note:

It is pointed out that Engine Testing was carried out with different Ambient Temperatures as indicated in Figure 3 below, which may have affected the Test Results to some extent. The Engine Test for each Blend was repeated more than once and Average Values have been indicated eliminating outliers.

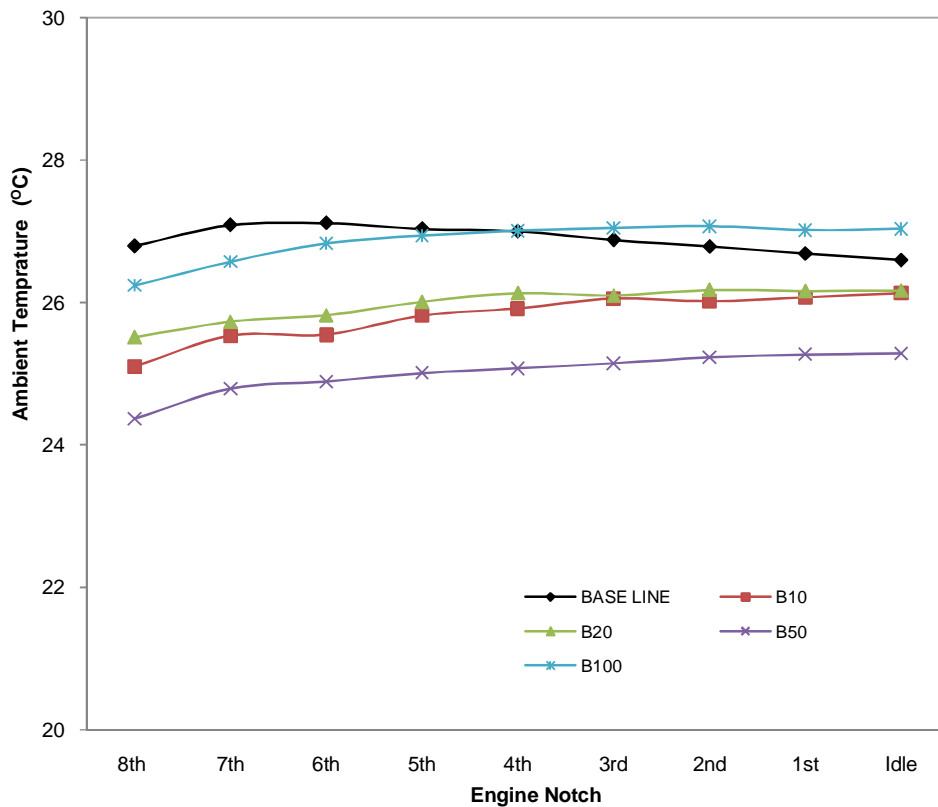

Figure 3: Variation of Ambient Air Temperature

Brake Specific Fuel Consumption:

Brake Specific Fuel Consumption (BSFC) has increased with the increase in Bio-Diesel percentage as already indicated in the Summary Table before (Table 5). Detailed analysis of Data has been undertaken to observe the effect of Engine rpm on Brake Specific Fuel Consumption. The observations of Brake Specific Fuel Consumption (gm/bhp-hr) for various Bio-Diesel Blends at different Notches are tabulated below:

Engine Notch	Normal HSD	Bio-Diesel Blends with High Speed Diesel (HSD)			
		B10	B20	B50	B100
8 th	157.0	158.6	160.3	167.8	177.1
7 th	157.9	159.7	161.7	169.1	178.7
6 th	165.1	166.6	169.3	176.7	187.7
5 th	173.3	175.2	178.1	187.1	199.2
4 th	181.9	181.7	184.9	195.4	209.2
3 rd	188.1	188.3	192.1	203.5	216.4
2 nd	194.9	195.7	200.6	212.4	225.0
1 st	211.7	217.1	223.3	235.2	249.7
Idle	233.8	243.9	246.5	258.9	274.5

Table 6: Comparison of Brake Specific Fuel Consumption (gm/bhp-hr) at different Notches

It can be seen that Brake Specific Fuel Consumption (BSFC) increases for higher Blends of Bio-Diesel. The Lower Heating Value (LHV) of Bio-Diesel is 10-12% less as compared to HSD and has resulted in increase in Brake Specific Fuel Consumption.

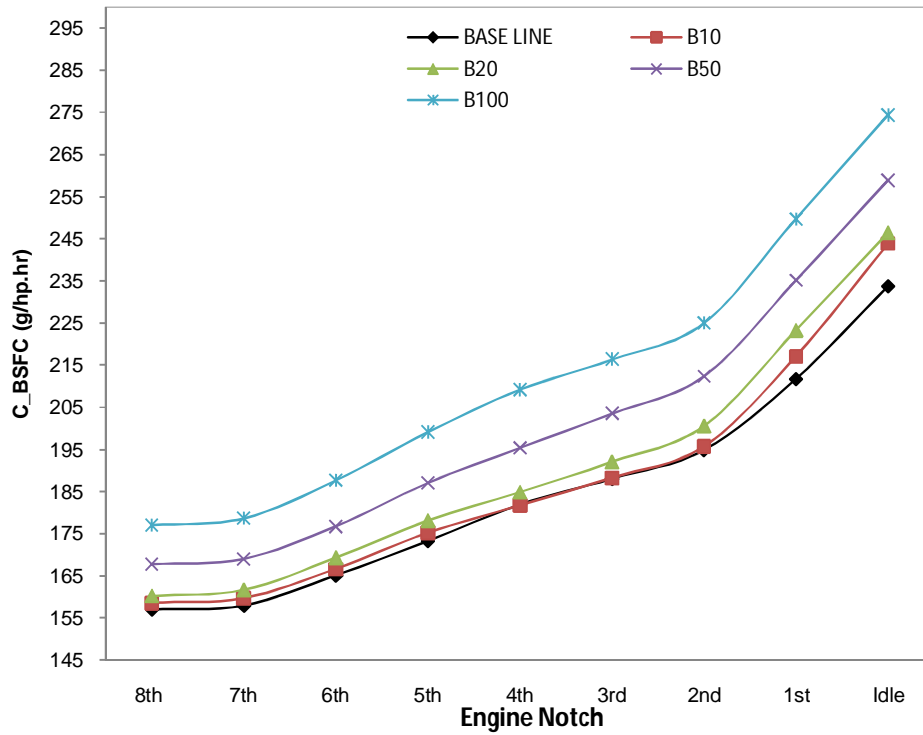

Figure 4: Comparison of Brake Specific Fuel Consumption (gm/bhp-hr) at different Notches

The graph of Brake Specific Fuel Consumption (BSFC) plotted against each Notch is shown in Figure 4 above. It can be seen from the above Figure that BSFC increases with higher Blends of Bio-Diesel. There is marginal difference in BSFC of Normal HSD and B10 Bio-Diesel.

Exhaust Gas Temperature:

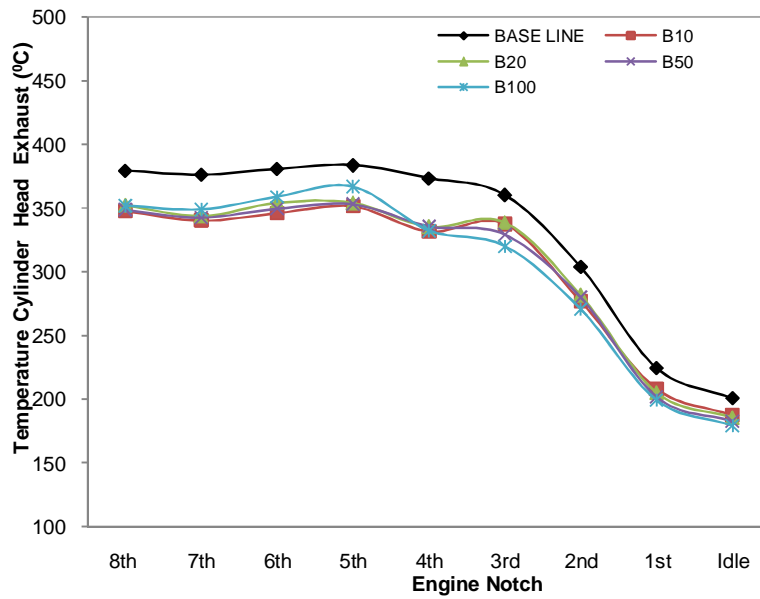

Figure 5: Comparison of Exhaust Gas Temperature

The variation of Exhaust Gas Temperature at Cylinder Head has been indicated in Figure 5. Exhaust Gas Temperatures were recorded for individual Cylinder Head. These were then averaged to plot the above Graph. The Temperatures are below the upper limit of 450°C.

Engine Notch	Normal HSD	Bio-Diesel Blends with HSD			
		B10	B20	B50	B100
8 th	379.5	347.9	352.5	348.7	351.8
7 th	376.3	340.4	343.9	342.7	349.0
6 th	380.8	346.2	354.4	349.7	358.9
5 th	383.8	351.5	354.2	353.1	366.8
4 th	373.6	331.9	335.6	335.9	332.4
3 rd	360.5	337.7	338.9	329.4	320.2
2 nd	303.8	276.9	281.8	280.1	270.7
1 st	224.5	208.1	205.2	201.9	199.3
Idle	200.7	187.4	185.4	182.6	179.1

Table 7: Comparison of Exhaust Gas Temperature

Turbine Gas Inlet Temperature:

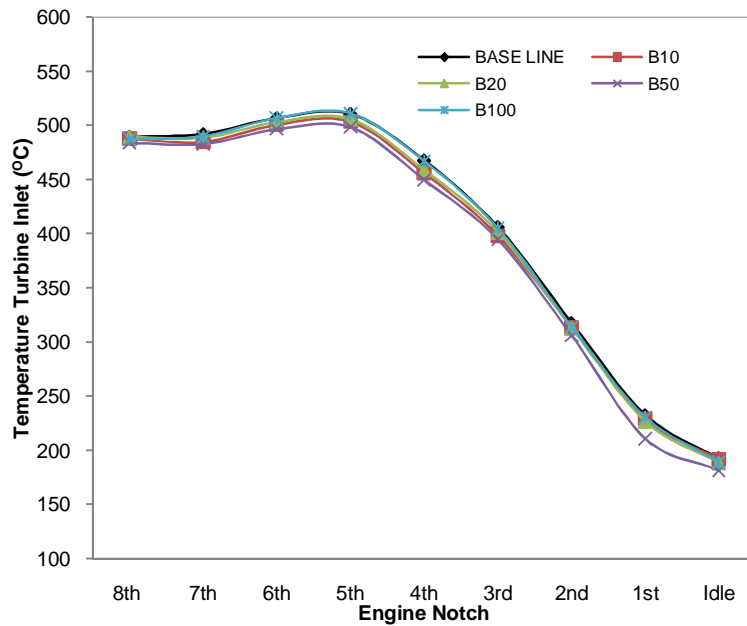

Figure 6: Comparison of Turbine Gas Inlet Temperature

Figure 6 above and Table 8 show the Turbine Gas Inlet Temperature. Correlation of Turbine Gas Inlet Temperature with Average Cylinder Head Exhaust Temperature is fair and these Temperatures are found to be higher than Cylinder Head Exhaust Temperatures.

Engine Notch	Normal HSD	Bio-Diesel Blends with Normal HSD			
		B10	B20	B50	B100
8 th	489.4	487.8	489.8	480.6	487.4
7 th	492.0	484.9	488.6	480.3	489.7
6 th	506.5	500.7	503.2	494.4	506.8
5 th	510.4	503.6	505.7	498.6	510.8
4 th	467.6	456.0	458.8	450.5	466.8
3 rd	405.8	398.0	401.4	396.0	404.8
2 nd	317.4	313.6	312.6	307.0	313.8
1 st	232.3	228.8	226.7	211.2	230.2
Idle	192.1	191.6	188.3	181.6	188.8

Table 8: Comparison of Turbine Gas Inlet Temperature (°C)

Boost Pressure:

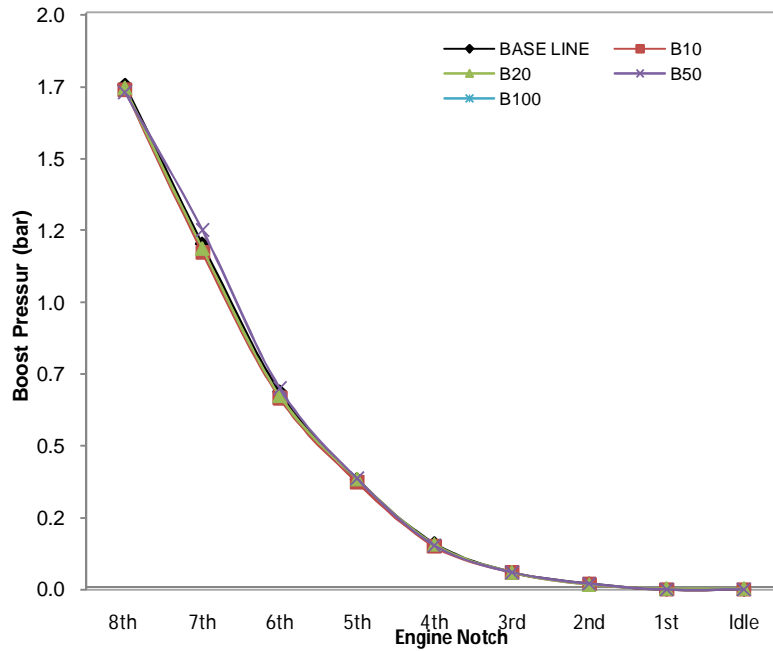

Figure 7: Comparison of Boost Pressure

Figure 7 shows the variation of Boost Pressures with various Blends of Bio-Diesel plotted against Engine Notch. There is almost no variation as far as Boost Pressures are concerned. Thus, Bio-Diesel and its Blends do not adversely affect performance of Turbocharger.

Engine Notch	Normal HSD	Bio-Diesel Blends with Normal HSD			
		B10	B20	B50	B100
8 th	1.7	1.7	1.7	1.7	1.7
7 th	1.2	1.2	1.2	1.2	1.2
6 th	0.7	0.7	0.7	0.7	0.7
5 th	0.4	0.4	0.4	0.4	0.4
4 th	0.2	0.1	0.1	0.1	0.2
3 rd	0.1	0.1	0.1	0.1	0.1
2 nd	0.0	0.0	0.0	0.0	0.0
1 st	0.0	0.0	0.0	0.0	0.0
Idle	0.0	0.0	0.0	0.0	0.0

Table 9: Comparison of Boost Pressure (bar)

Fuel Injection Pump – High Pressure Line Pressure:

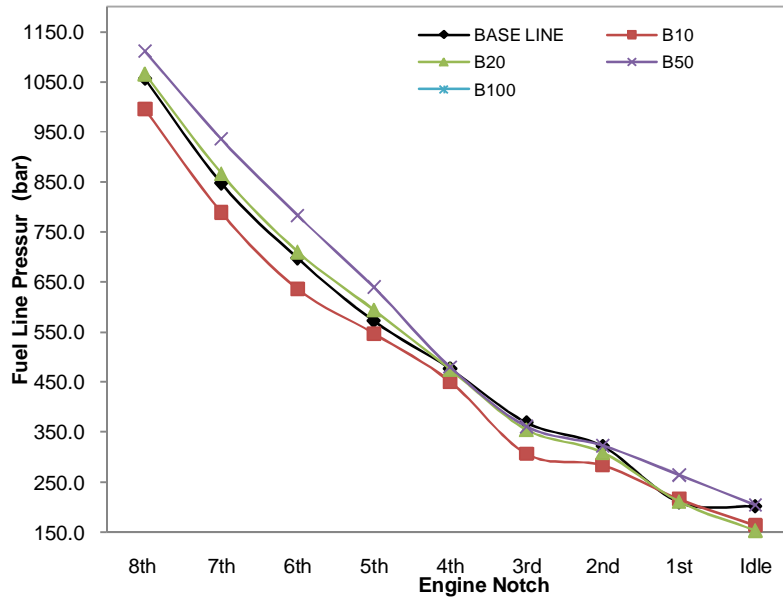

Figure 8: Comparison of Fuel Line Pressure

Engine Notch	Normal HSD	Bio-Diesel Blends with Normal HSD			
		B10	B20	B50	B100
8 th	1056.6	995.3	1066.1	1111.8	1164.0
7 th	847.1	788.8	866.5	935.6	959.6
6 th	697.4	635.9	710.0	783.1	803.6
5 th	571.9	546.9	594.1	639.4	677.4
4 th	476.4	451.0	475.4	479.9	556.0
3 rd	368.9	306.9	354.6	361.1	404.0
2 nd	321.6	283.6	308.8	322.7	379.2
1 st	209.6	216.6	211.1	264.0	280.0
Idle	201.2	163.8	153.2	204.0	221.8

Table 10: Comparison of Fuel High Pressure Line Pressure (bar)

The variation of Fuel Line Pressure with different Blends of Bio-Diesel and HSD are indicated in Figure 8 and Table 10 above. Higher Blends have shown higher Fuel Line Pressures due to increase in viscosity because of blending of Petro-diesel with Bio-Diesel.

NOx Emissions:

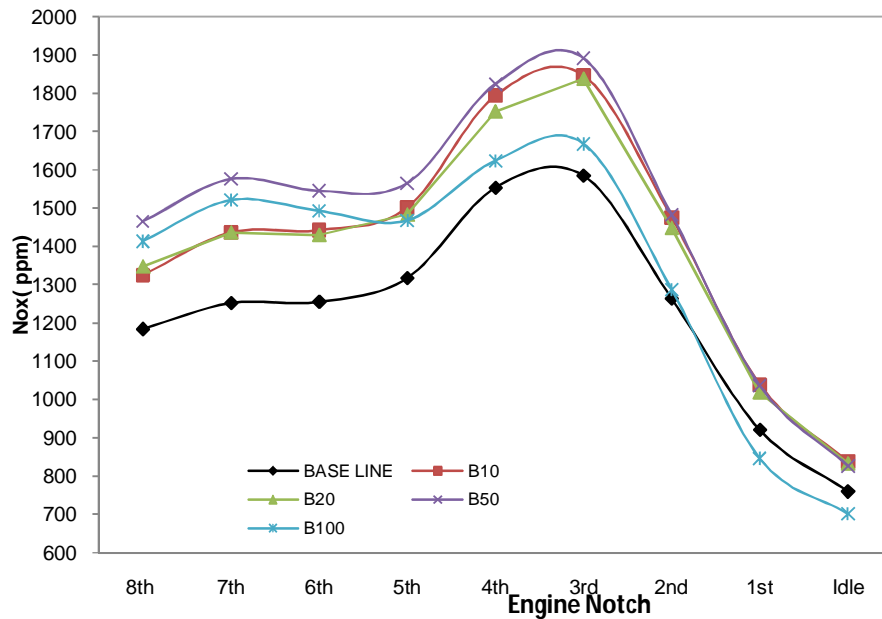

Figure 9: Comparison of NOx Emissions (ppm)

Figure 9 and Table 11 show the variation of NOx Emissions with various Blends of Bio-Diesel at different Engine Notches. NOx Emissions increase with higher Blends of Bio-Diesel due to higher viscosity of Bio-Diesel leading to earlier Injection, earlier Combustion and also Bio-Diesel being an oxygenated Fuel facilitating NOx formation. There are non-thermal reasons also for increase of NOx. All Blends of Bio-Diesel show higher NOx levels after 2nd Notch as compared to Normal HSD.

Engine Notch	Normal HSD	Bio-Diesel Blends with Normal HSD			
		B10	B20	B50	B100
8 th	1184.0	1324.7	1347.4	1464.6	1412.7
7 th	1251.6	1435.7	1436.3	1575.9	1520.1
6 th	1255.2	1442.1	1429.9	1545.0	1492.2
5 th	1317.0	1500.6	1482.9	1564.8	1467.4
4 th	1553.2	1793.2	1752.3	1823.5	1623.0
3 rd	1584.7	1846.4	1837.9	1891.0	1667.3
2 nd	1263.2	1475.4	1448.0	1482.4	1286.7
1 st	920.2	1038.8	1018.3	1036.9	845.6
Idle	759.4	837.6	832.4	827.2	700.9

Table 11: Comparison of NOx Emissions (ppm)

Total Hydrocarbon (THC) Emissions:

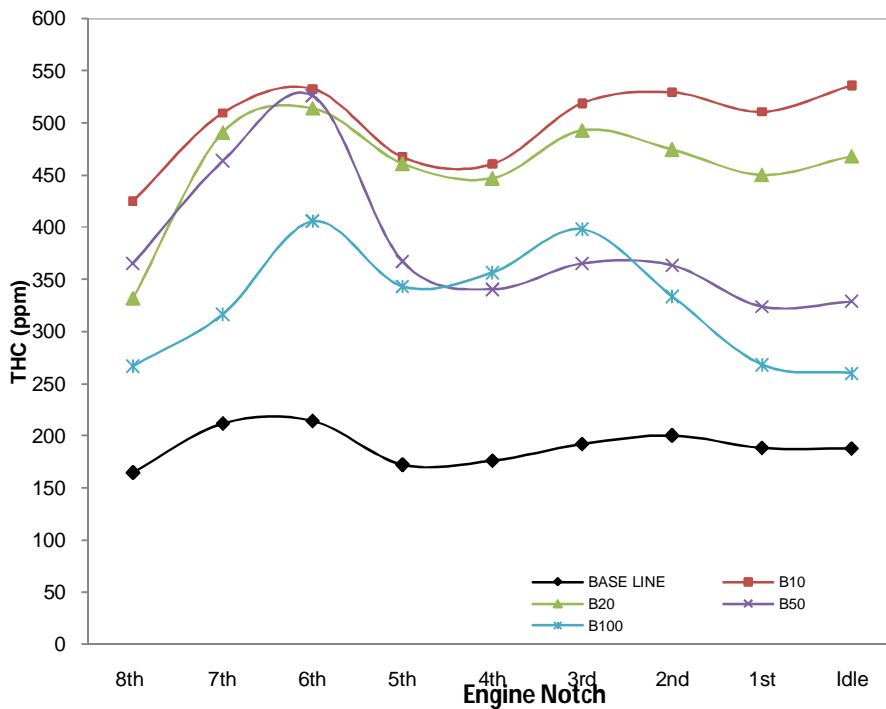

Figure 10: Comparison of Total Hydrocarbon Emissions

Engine Notch	Normal HSD	Bio-Diesel Blends with Normal HSD			
		B10	B20	B50	B100
8 th	164.9	425.0	331.8	365.3	266.6
7 th	211.7	509.4	490.7	463.6	316.4
6 th	214.1	532.5	514.1	526.0	405.6
5 th	172.4	467.2	460.9	367.2	343.1
4 th	176.1	460.5	446.9	340.3	356.4
3 rd	192.0	518.8	492.9	365.2	397.9
2 nd	200.2	529.3	474.5	363.3	333.7
1 st	188.3	510.5	450.1	323.8	268.0
Idle	187.7	535.9	468.1	328.6	259.8

Table 12: Comparison of THC Emissions (ppm)

As can be seen from Figure 10 and Table 12 above, B100 Blend of Bio-Diesel has, shown the lowest Total Hydrocarbons (THCs) as compared to various blends of Bio-Diesel.

CO Emissions:

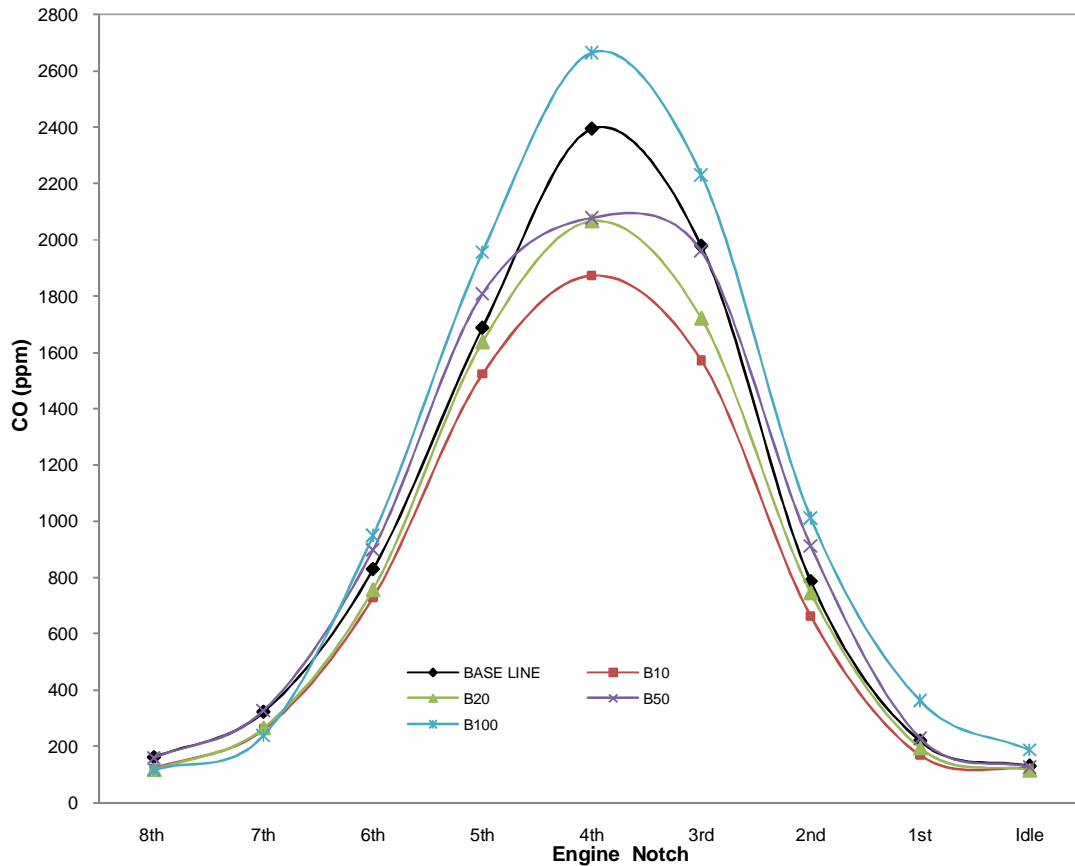

Figure 11: Comparison of CO Emissions

Engine Notch	Normal HSD	Bio-Diesel Blends with Normal HSD			
		B10	B20	B50	B100
8 th	161.5	123.2	116.3	158.5	117.1
7 th	322.8	260.7	265.6	326.9	238.8
6 th	829.5	729.3	757.1	898.6	949.1
5 th	1687.6	1523.5	1637.6	1808.3	1956.3
4 th	2395.5	1873.9	2067.4	2078.7	2665.0
3 rd	1978.7	1571.6	1721.7	1960.3	2231.7
2 nd	787.3	663.1	746.2	912.3	1011.8
1 st	219.1	168.9	193.7	228.0	362.5
Idle	130.0	120.6	115.1	125.6	186.9

Table 13: Comparison of CO Emissions (ppm)

Variation of CO Emissions with Engine Loading for different Fuel is indicated in Figure 11 and Table 13 above. It is found that there is reduction of 27.5 % in CO Emissions at 8th Notch with B100 Bio-Diesel as compared to Normal High Speed Diesel. This reduction in CO Emissions at 8th Notch with B100 Bio-Diesel is due to more complete oxidation as compared to HSD. Increase in CO Emissions from 3rd to 5th Notch for various blends of Bio-Diesel and HSD is noticed.

Smoke Opacity:

Figure 12: Comparison of Smoke Opacity

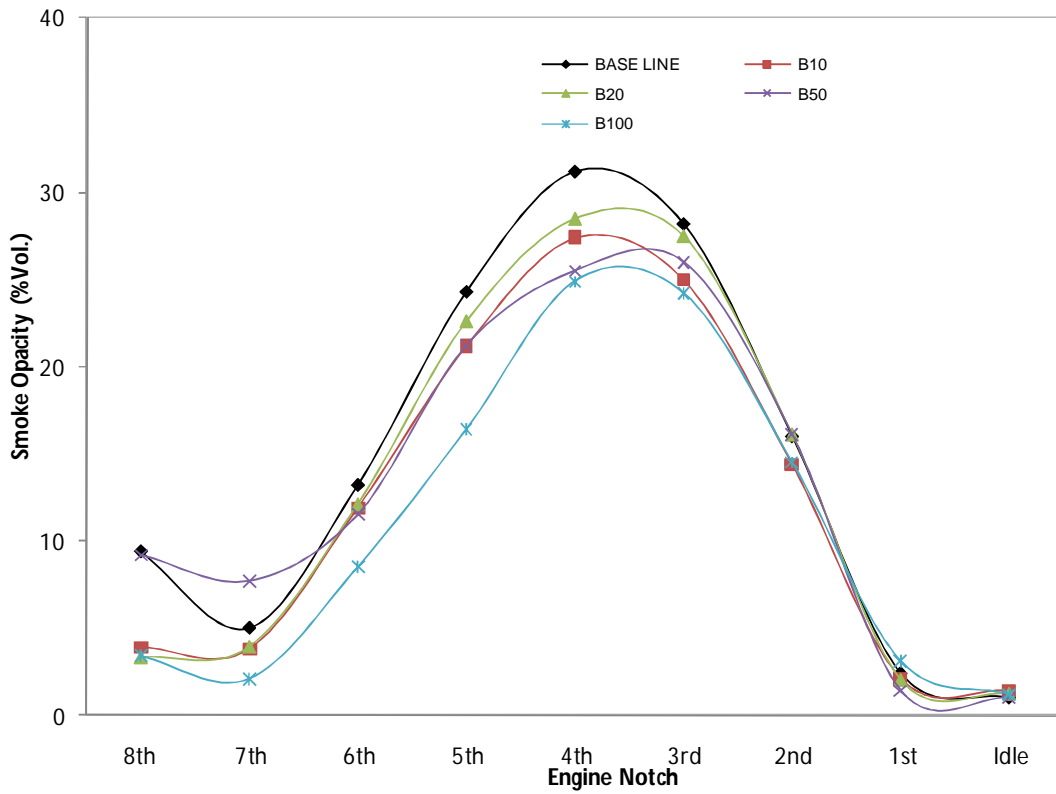

Figure 12 above shows Smoke Opacity values obtained with different Blends of Bio-Diesel. It can be clearly seen that Smoke Opacity decreases with higher Blends of Bio-Diesel which corroborates well with the fact that Esters are oxygenated Fuels. There is 63.8% reduction in Smoke Opacity with B100 Bio-Diesel as compared to Normal HSD (at 8th Notch).

Engine Notch	Normal HSD	Bio-Diesel Blends with Normal HSD			
		B10	B20	B50	B100
8 th	9.4	3.9	3.3	9.2	3.4
7 th	5.0	3.8	3.9	7.7	2.1
6 th	13.2	11.9	12.1	11.5	8.5
5 th	24.3	21.2	22.6	21.2	16.4
4 th	31.2	27.4	28.5	25.5	24.9
3 rd	28.2	25.0	27.5	26.0	24.2
2 nd	16.0	14.4	16.1	16.1	14.5
1 st	2.4	2.1	2.0	1.4	3.1
Idle	1.0	1.4	1.2	1.0	1.2

Table 14: Comparison of Smoke Opacity Emissions (% Volume)

Filter Condition:

No abnormal deposits were observed on the Filter(s) and no change of Filter(s) was undertaken. Differential pressure across Filter did not increase more than the stipulated value.

CONCLUSION:

The Performance Studies with different Blends of 'Pongamia Oil' based Bio-Diesel carried out on 3100 HP ALCO Engine reveal the following:

1. There is no change in Horsepower for various Blends of Bio-Diesel. Even B100 Bio-Diesel is capable of developing full Horsepower on 3100 HP ALCO Engine.
2. Brake Specific Fuel Consumption (BSFC) showed an increasing trend with higher Blends of Bio-Diesel as compared to Petro-Diesel. BSFC has increased by 12.8% at 8th Notch with B100 Bio-Diesel as compared to Petro-Diesel, which is due to 10 -12% Lower Calorific value of Ester Fuel (Bio-Diesel) as compared to Petro-Diesel.
3. Total Hydrocarbon (THC) Emissions revealed decreasing trend with higher Blends of Bio-Diesel.
4. NOx Emissions generally increase with higher Blends of Bio-Diesel due to higher viscosity of Bio-Diesel leading to earlier Injection/Combustion and Bio-Diesel being oxygenated Fuel facilitating NOx formation. All Blends of Bio-Diesel show higher NOx levels after 2nd Notch as compared to Normal HSD.
5. CO Emissions have reduced by 27.5% at 8th Notch with B100 Bio-Diesel as compared to HSD. This reduction in CO Emissions at 8th Notch with B100 Bio-Diesel is due to complete oxidation as compared to HSD. Increase in CO Emissions from 3rd to 5th Notch for various blends of Bio-Diesel and HSD is noticed.
6. Smoke Opacity of Exhaust showed decreasing trend with higher Blends of Bio-Diesel with 63.8% reduction with B100 Bio-Diesel as compared to Normal HSD (at 8th Notch).
7. Average Cylinder Head Exhaust Temperatures have varied over narrow range and were found below upper limit of 450 °C.
8. The performance of Fuel Injection Equipment and Rubber/Brass Components need to be monitored with usage of Bio-Diesel. Proper Handling, Storage and Transportation of Bio-Diesel need to be ensured so that Bio-Diesel does not deteriorate due to oxidation.